

Leadership by tradition.



SERVICE MANUAL

UHF CONTINUOUS DUTY RF POWER AMPLIFIERS

**3370 SAN FERNANDO RD., #206
LOS ANGELES, CA 90065
TEL: (323)-256-3000 FAX: (323)-254-3210
E Mail: tplcom@usa.net**

L-PA6-CD-S/C1

TABLE OF CONTENTS

OPTIONS	2
CAUTION	5
GENERAL SPECIFICATIONS	6
OPERATING PRECAUTIONS	8
INSTALLATION	8
CIRCUIT DESCRIPTION.....	9
AMPLIFIERS STAGE LINE-UP DIAGRAM	11
TEST SET UP DIAGRAM	12
TUNE-UP INSTRUCTIONS	13
COMPONENT LAYOUT	14
SCHEMATIC DIAGRAMS	15
WIRING DIAGRAMS	22
PARTS LIST	25
WARRANTY	34

OPTIONS

TPL Communications' UHF Continuous Duty RF Power Amplifiers are available with several options: input, output, voltage, frequency ranges, and configurations, special logos, etc., when specified at the time of order. We work closely with you, our customer, to develop products that are in complete compliance with your needs and specifications.

PACKAGE OPTIONS:

- RXR:** Extruded aluminum heat sink. No fan needed.
19"W x 7"H x 3 ½"D
- RXRPS:** Same as "RXR," but with integral 25 Ampere power supply.
19"W x 7"H x 8"D
- RXRF:** Same as "RXR," but with a 13.8 VDC cooling fan.
19"W x 7"H x 5"D
- RXRF2:** Same as "RXR," but with two 13.8 VDC cooling fans.
19"W x 7"H x 5"D
- RXRFPS:** Same as "RXRPS", but with a 13.8 VDC cooling fan.
19"W x 7"H x 8"D
- RXRF2PS:** Same as "RXRPS", but with two 13.8 VDC cooling fans.
19"W x 7"H x 8"D
- RS:** Extruded aluminum heat sink. No fan needed.
19"W x 5¼"H x 27/8"D
- RSPS:** Same as "RS", but with integral 10 Ampere power supply.
19"W x 5¼"H x 9 ½"D
- RXHF3:** Extruded aluminum heat sink with two front and one rear fan.
19"W x 14"H x 7"D
- RXHF3PS:** Same as "RXHF3", but with model-dependant switching power supply.
19"W x 14"H x 9.5" (or 12") D

OPTIONS
(continued)

SOLID STATE COR OPTION - SSR

A solid state carrier operated relay is available on some models if specified.

*Other variations and options are available; contact TPL for further information.

NOTE: All TPL standard UHF series amplifiers are factory-tuned to the frequency specified at the time of order and will operate within minimum ± 10 MHz of that frequency unless otherwise specified. Many models are available with lower input drive level. Contact Manufacturer for details.

Radio Properties

**Two-Way Radio: Sales, Rental, Leasing,
Parts, Repairs and Specialized Electronics.
Repeater Access & Vault Space.**

KENWOOD *Authorized Sales & Service*

Skipp May P.O. Box 192

Elmira, CA. 95625

**Voice (707) 678-4187 - Fax (707) 693-8057
nospam4me@juno.com www.radiowrench.com**

OPTIONS
(continued)

RS

Extruded aluminum heat sink. No fan needed.

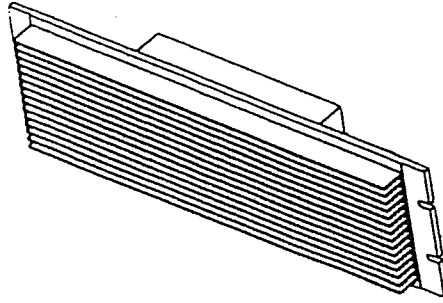

RXR

Extruded aluminum heat sink. No fan needed.

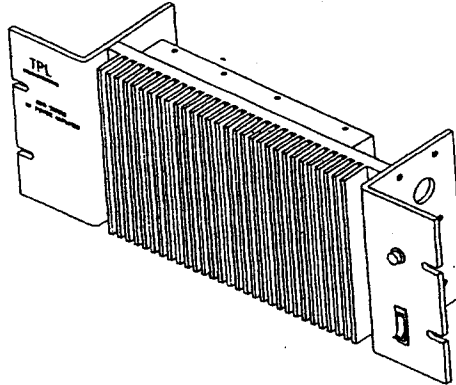

RXRFPS

Same as "RXRF," but with a 13.8 VDC power supply.

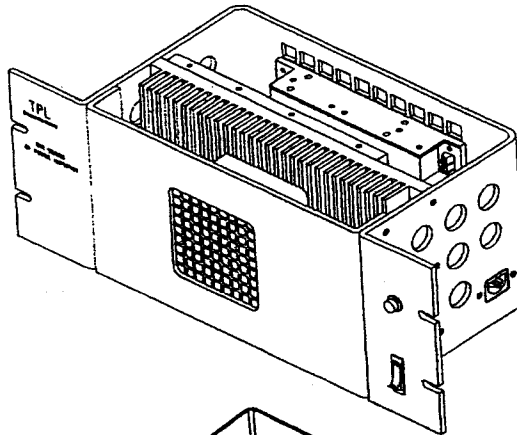

RXHF3

Extruded aluminum heat sink. With three cooling fans.

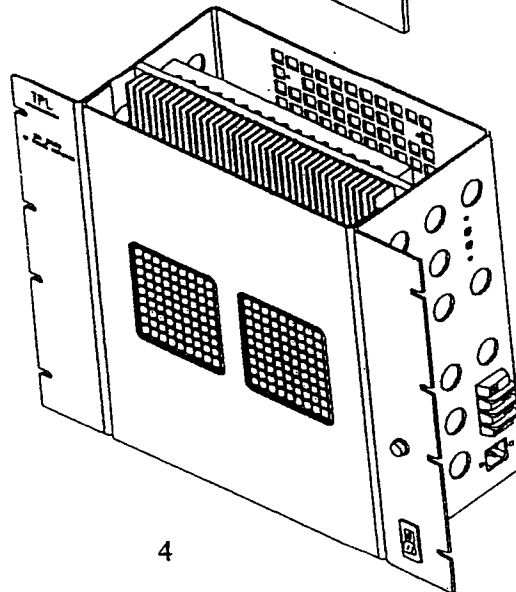

CAUTION!

Inspect the amplifier thoroughly upon receipt for visible damage. If any is noticed, please call **TPL Communications** at **800 HI POWER** to request an **RMA** (Return Material Authorization) number. If purchased through a dealer or distributor, ask them to also follow this procedure for best results.

EXPENSIVE COMPONENTS MAY BE DESTROYED IF THE AMPLIFIER IS TURNED ON IN A DAMAGED CONDITION.

GENERAL SPECIFICATIONS

CONTINUOUS DUTY UHF POWER AMPLIFIERS

FREQUENCY RANGE: 400 - 512 MHz

MODEL	POWER INPUT	POWER OUTPUT	CURRENT	PRIMARY VOLTAGE
PA6-1EE-RXRF	75-150 mW	70-100 W	24 Amp.	13.8 VDC
PA6-1AB-RS	1-4 W	10-25 W	4 Amp.	13.8 VDC
PA6-1AC-RS	1-4 W	25-50 W	8 Amp.	13.8 VDC
PA6-1AC3-RS	4-8 W	25-50 W	8 Amp.	13.8 VDC
PA6-1AE-RXRF	1-4 W	70-100 W	20 Amp.	13.8 VDC
PA6-1BC-RS	8-15 W	25-50 W	7 Amp.	13.8 VDC
PA6-1BE-RXRF	8-15 W	70-100 W	16 Amp.	13.8 VDC
PA6-1FE-RXRF	25-40 W	60-100 W	15 Amp.	13.8 VDC
PA6-1XF-RXHF3*	1-60 W	200 W	N/A	13.8 VDC
PA6-2XF-RXHF3*	5-45 W	300 W	N/A	28 VDC

1. *Input level should be specified at the time of order.
2. Power Supplies are available for all models as PS option.

OPERATING MODE:

FM / CW

OPERATING VOLTAGE:

13.8 VDC or with 110 VAC / 220 VAC power supplies available if required.
(PS option).

EIA DUTY CYCLE:

100% / Continuous

HARMONIC & SPURIOUS ATTENUATION:

Meets or exceeds FCC Type Acceptance requirements.

IN/OUT IMPEDANCE:

50 Ohms.

IN/OUT RF CONNECTORS:

Type "N"

GENERAL SPECIFICATIONS
(continued)

RECEIVER PATH INSERTION LOSS:

1 dB maximum when the optional Carrier Operated Relay (COR) is specified.

CONFIGURATION:

Repeater configuration is standard and it is supplied without a COR. Base station configuration is optional and it is supplied with COR.

CIRCUIT PROTECTION:

Provided by a circuit breaker or a fuse with model-dependant current rating.

OPERATING TEMPERATURE RANGE:

-20° to +50° Celsius.

STORAGE TEMPERATURE:

-40° to +85° Celsius.

OPERATING HUMIDITY:

0% - 85% RH (non-condensing).

STORAGE HUMIDITY:

0% - 95% RH (non-condensing).

OPERATING PRECAUTIONS

- CAUTION:** This amplifier produces RF voltages that can cause painful and dangerous RF burns. Use caution! Connect and disconnect all RF connections with the DC power and drive power off.
- DRIVE POWER:** RF power transistors, although quite rugged in most respects, are easily damaged by overdrive. Be careful not to overdrive this amplifier, even for an instant. Higher-than-rated drive power may destroy the transistors and **VOID ANY WARRANTY**.
- TERMINATIONS:** The efficiency of this amplifier will degrade if it is operated into anything but a **50 Ω** load. Lowered efficiency may mean any or all of the following: lower power output, increased a current drain, higher operating temperature, and reduced life time.

INSTALLATION INSTRUCTIONS FOR CONTINUOUS DUTY AMP

This unit is designed for mounting in a standard 19" rack. When picking a location in the rack, consideration must be given to RF power output cable lengths, as well as cooling considerations.

Mount the unit where dust and other debris are not likely to clog the cooling fans. Avoid mounting the amplifier directly above hot pieces of equipment that could artificially raise the amplifiers temperature.

Connect the radio transmitter to the "**RF INPUT**" connector with a **50 Ω** cable and a type "**N**" plug. Connect the antenna to the "**RF OUTPUT**" connector on the amplifier with **50 Ω** coaxial cable and a type "**N**" plug.

Plug the AC line cord into the system AC power receptacle. If powered by a user-supplied **13.8 VDC** source, connection must be made with **#10 AWG** (or heavier) wiring.

For safety, ensure that the rack and all equipment connected to the amplifier have proper AC grounds. Do not rely on coaxial cable shielding. Assure the installation has proper lightning protection (e.g. in line coaxial protectors manufactured by PolyPhaser Corporation or equivalent).

CIRCUIT DESCRIPTION

The UHF Continuous Duty Power Amplifiers are comprised of a group 50 Ohm. modular building blocks as shown in Table 1. A brief description of each follows (See Appendix 1 for corresponding schematic diagram).

Pre-driver stage Part No. T-100327-P-D-SA **(Power output 15W Maximum at 13.8 VDC)**

This stage provides approximately 6dB of gain utilizing a common emitter bipolar RF transistor Q1. Input impedance matching of Q1 is accomplished by the combination of capacitors C1, C2, C3, C4 and microstrip line Z1. Output impedance matching is accomplished in a similar manner by capacitors C8, C9, C10 and microstrip line Z2. DC bypass and isolation are achieved by capacitors C6, C7, C11, C12, Inductors L2, L3 and resistors R1, and R3. A bias voltage from the bias circuit on the Relay board is supplied through L1, C5, and R1. If bias is not used the end of the L1 opposite to the Base of Q1 should be connected to ground. Input and output impedances are 50 Ohms.

Pre-driver stage Part No. T-101649-6-SA **(Used for PA6-1EE only)**

This pre-driver is used for low input drives (75-250 mW). It replaces pre-driver part number 100327-P-D-SA in PA6-1EE or other special amplifiers. This stage provides approximately 21 dB gain and consists of RF Power Hybrid Amplifier U1, which has a maximum power out of 30 watts, power control circuit C1, R1, R2, R3, U2, and DC bypass capacitors C2, C3, C4, C5, C6. Power output of this stage is preset by the pot. R3, to avoid an overdrive of the next stage. Input and output impedance are 50 Ohms.

Driver, Final stage Part No. T-1000327-D-SA, T-100327-F-SA **(Power Output - 60W, maximum)**

This stage provides approximately 5 dB of gain employing a common emitter bipolar RF Power transistor - Q1. Input impedance matching realized by capacitors: C1, C2, C3, C4 and microstrip line Z1. Output impedance matching is accomplished by capacitors C7, C8, C9, C10 and microstrip line Z2. DC bypass and isolation are accomplished through C5, C6, C11, C12, L2, L3, and R4. Inductor L1 provides a DC ground for the base of Q1 for class C operation. Input and output impedance are 50 Ohms.

Input Splitter / Output Combiner Part No. 100237-1

Power splitter / combiner is a classical two way coaxial Wilkinson combiner. It consists of two $\frac{1}{4}$ wave length 75 Ohms impedance coaxial cables T1, T2, and 100 Ohms balancing resistor R1. All inputs and output impedances are 50 Ohms.

Low Pass Filter (L.P.F.) Part No. 100134-LPF-SA

LPF is a seven pole Chebychev filter providing 45-55 dB of attenuation of the 2nd and higher harmonics.

CIRCUIT DESCRIPTION
(continued)

Antenna Switch Relay

Mechanical: Part No. T-00816-R-SA, T-100816-R-1-SA

Solid State: Part No. T-100371-UHF-SA

This circuit is activated by RF signal from the input of the amplifier through the combination of C1, C2, D1, D2 for Mechanical COR and C3, D3, R3, R4, Q1 for Solid State Relay. This antenna switch relay switches RF signal through the amplifier during transmit and bypass it during receive cycle. In mechanical antenna switch relay it is accomplished by relay K1 and K2 and in Solid State Relay - by PIN diodes D1, D2, D4, and D5. When specified the relay may be configured to bypass the amplifier in case of input AC or DC power failure.

UHF RF POWER AMPLIFIERS STAGE LINE - UP.

TABLE 1.

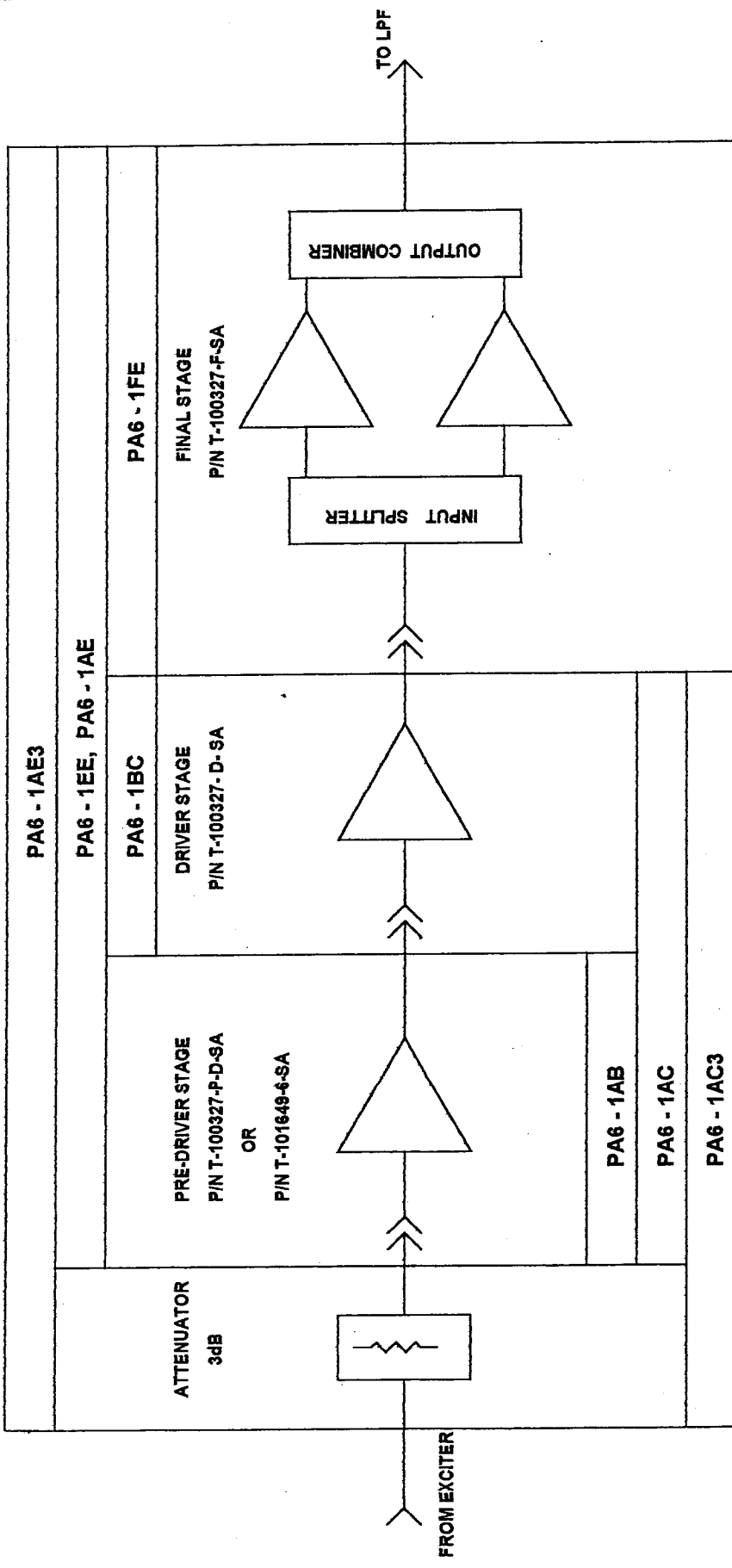

AMPLIFIER TEST AND ADJUSTMENT SET UP DIAGRAM

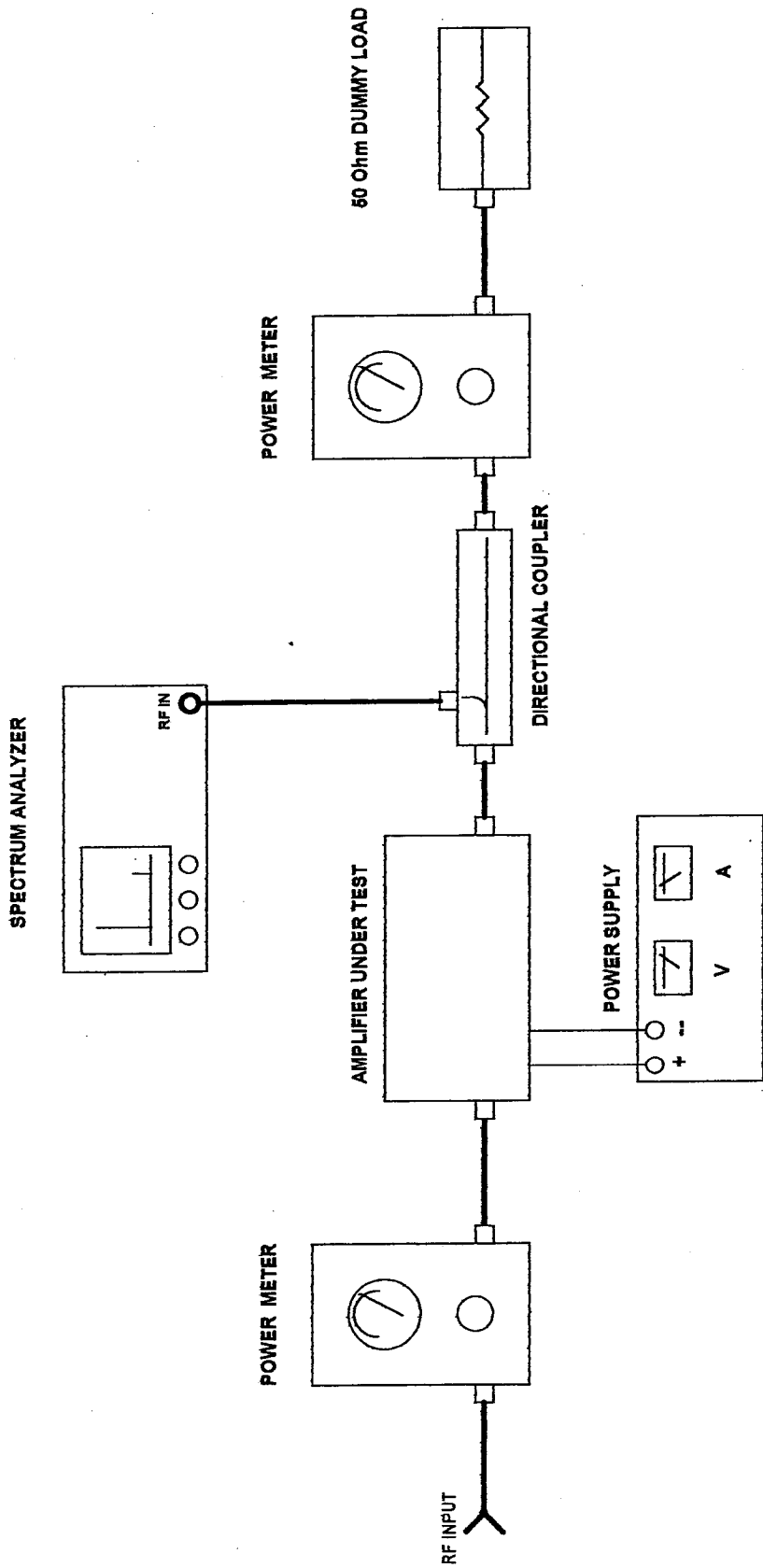

TUNE-UP INSTRUCTIONS

All TPL UHF Continuous Duty Power Amplifiers are comprised of 50 Ohm building blocks and combined in various ways to make up the various models (see Table 1). This approach makes a tune-up very simple.

Since layout of the PCB for pre-driver, driver and final stages are practically the same. The tuning procedures for all these stages consist of 3 basic steps.

STEP	ADJUST	FUNCTION	INSTRUCTIONS
1	C2	Input impedance matching.	Tune for minimum VSWR.
2	C9	Output impedance matching.	Tune for maximum output power.
3	C2, C9	Optimization Frequency spectrum observation.	Repeat steps 1 and 2 for minimum VSWR, maximum Power and maximum efficiency. Observe a signal on a spectrum analyzer at all times for any signs of oscillation, harmonics or spurious emission.

Radio Properties

Two-Way Radio: Sales, Rental, Leasing,
Parts, Repairs and Specialized Electronics.
Repeater Access & Vault Space.

KENWOOD *Authorized Sales & Service*

Skipp May P.O. Box 192

Elmira, CA. 95625

Voice (707) 678-4187 - Fax (707) 693-8057
nospam4me@juno.com www.radiowrench.com

COMPONENT LAYOUT

PRE-DRIVER STAGE P/N T-100327-P-D-SA

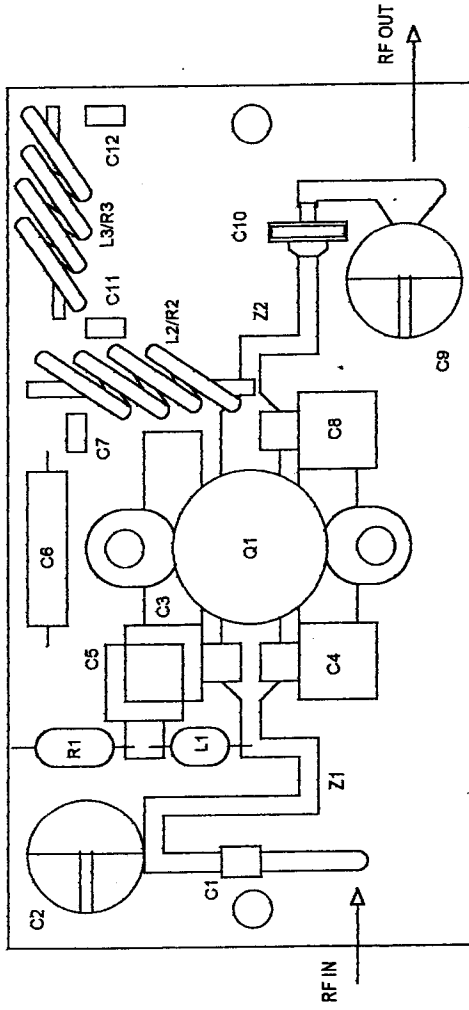

DRIVER, FINAL STAGE P/N T-100327-F-SA

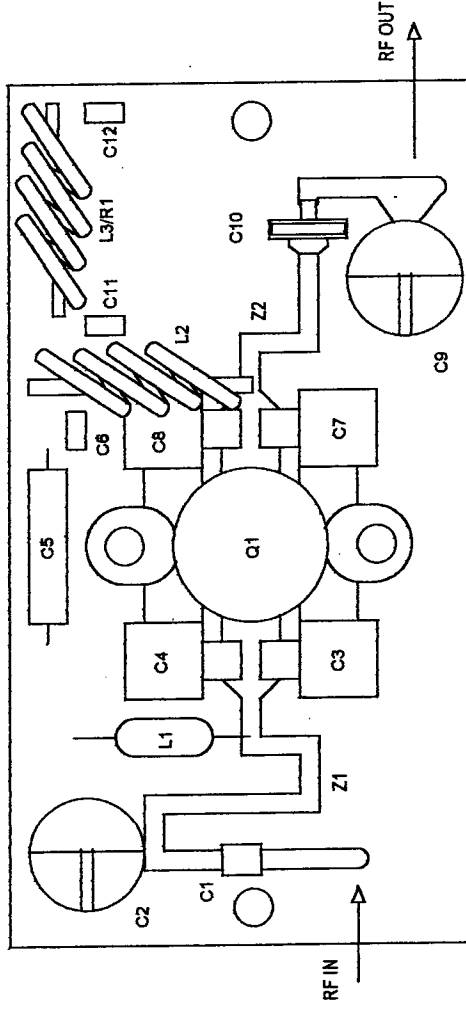

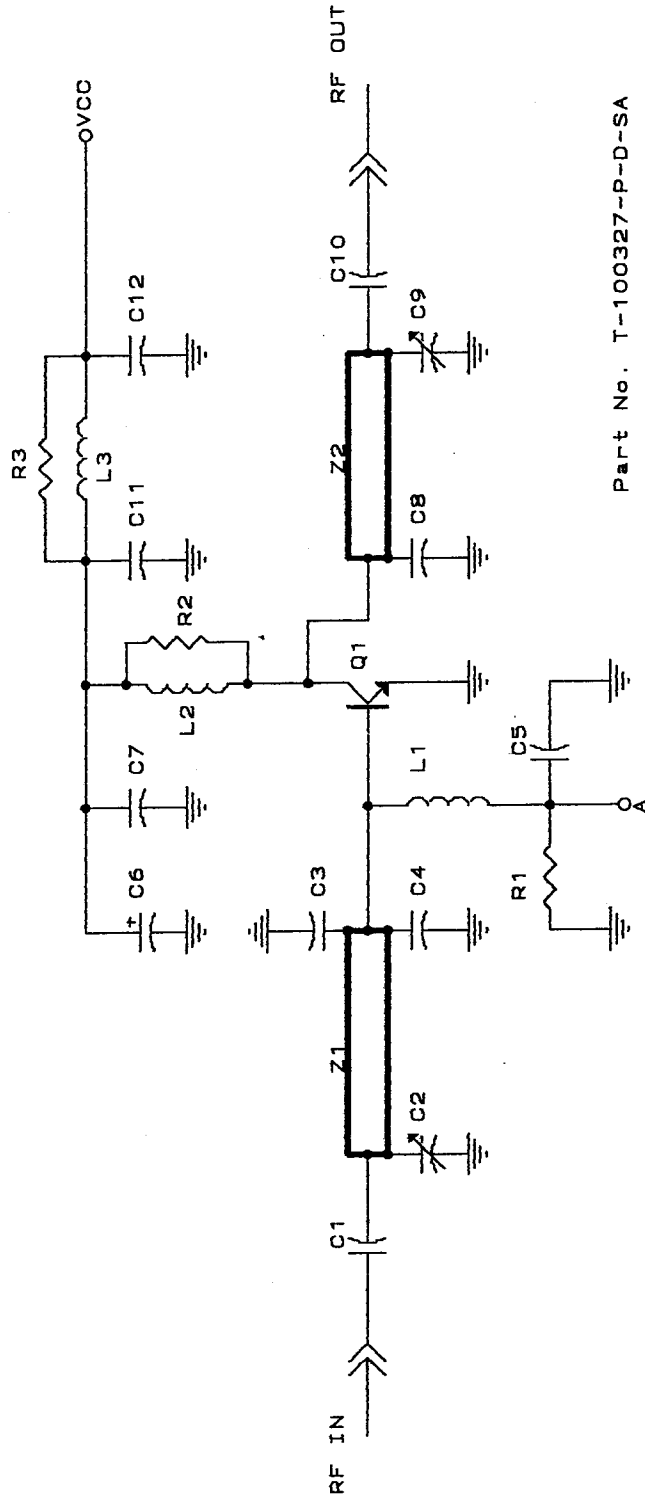

Part No. T-100327-P-D-SA

NOTES:

1. POINT A IS A BIAS INPUT FROM FROM A BIAS NETWORK ON RELAY BOARD
2. ON PA6-1AC POINT A IS CONNECTED TO GROUND
3. R1 AND C5 USED ONLY ON PA6-1AE

UHF DVR

T P L COMMUNICATIONS

Title PRE-DRIVER STAGE SCHEMATIC DIAGRAM

Size Document Number A

REV

Date: March 21, 2001 Sheet of

**PRE-DRIVER STAGE P/N T-101649-6-SA
SCHEMATIC DIAGRAM**

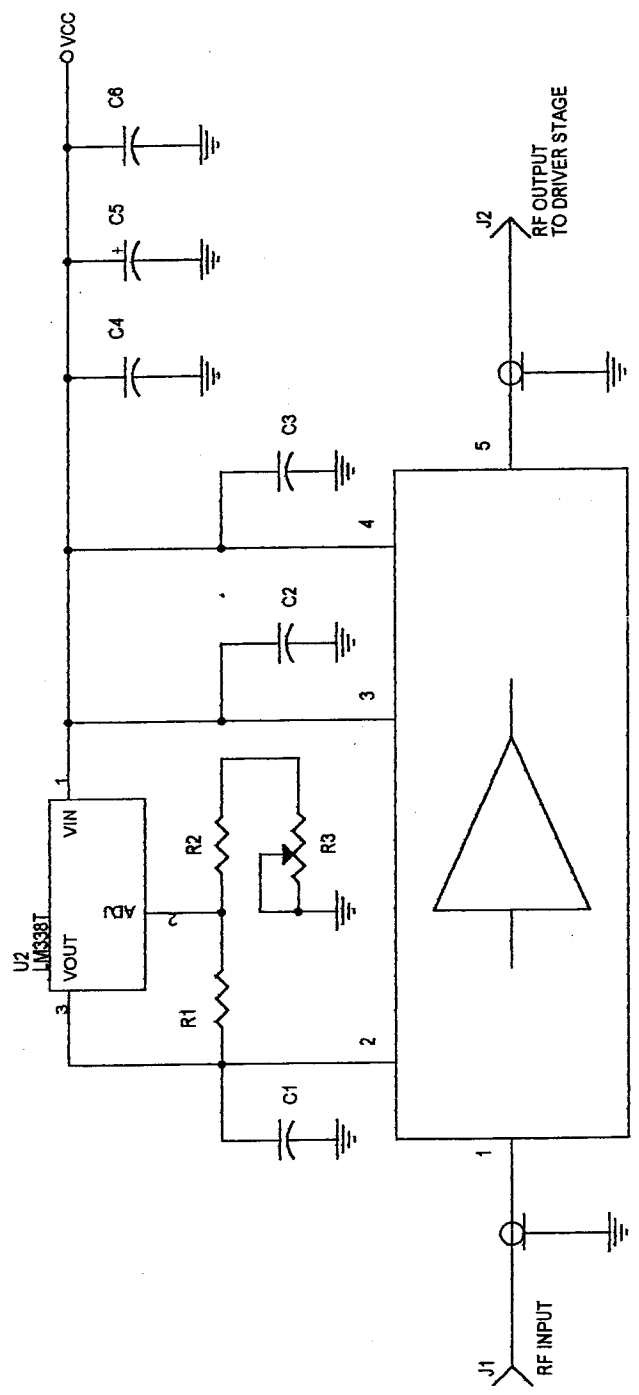

U1
M57729 OR EQUIV.

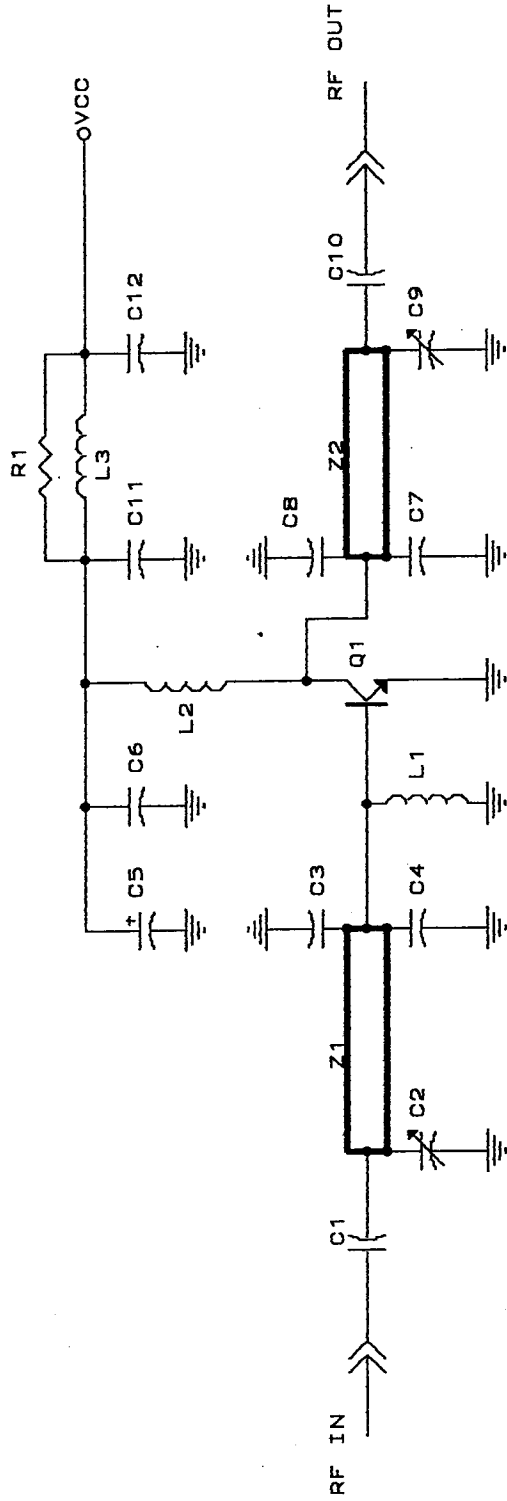

Part No. T-100327-D-1-SA, T-100327-F-SA

Title		T P L COMMUNICATIONS
DRIVER/FINAL STAGE SCHEMATIC DIAGRAM		
Size	Document Number	REV
A		
Date:	March 21, 2001	Sheet of

UHFPA

2 WAY POWER SPLITTER

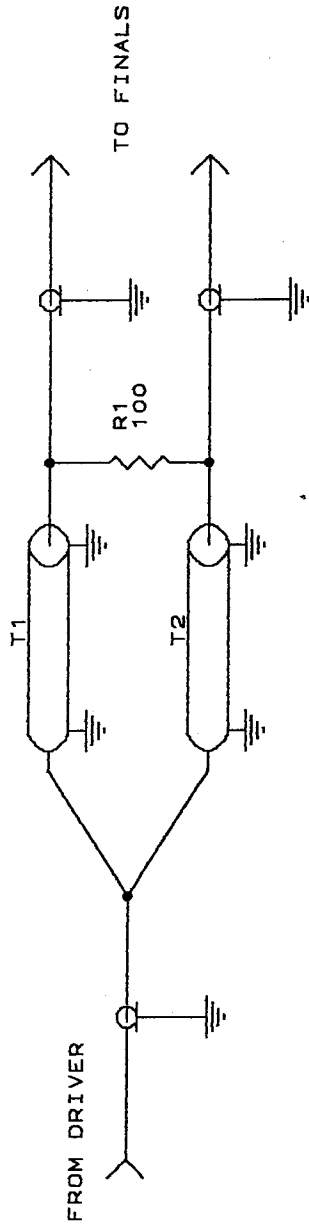

2 WAY POWER COMBINER

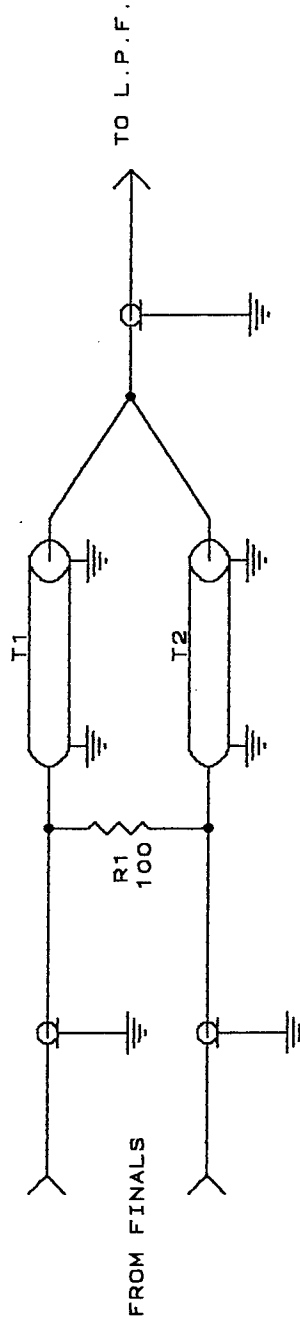

Title		T P L COMMUNICATIONS
Size		A
Document Number		PA6COMB.SCH
REV		2 WAY SPLITTER/COMBINER SCHEMATIC DIA.
Date:	March 21, 2001	Sheet of

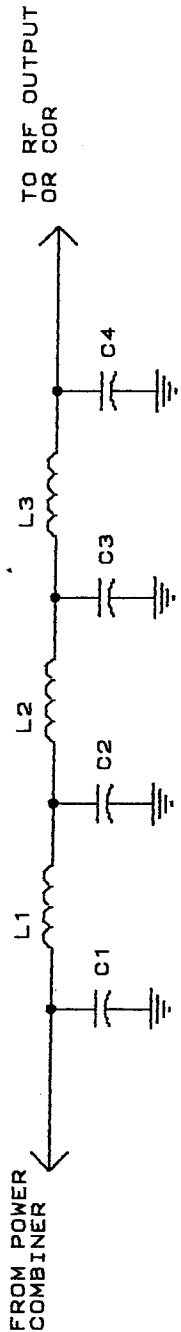

T P L COMMUNICATIONS	
Title	UHF LOW PASS FILTER SCHEMATIC DIA.
Size	Document Number 101383
REV	A
Date	March 13, 2001

PA6LPF.SCH

Sheet 13 of 19

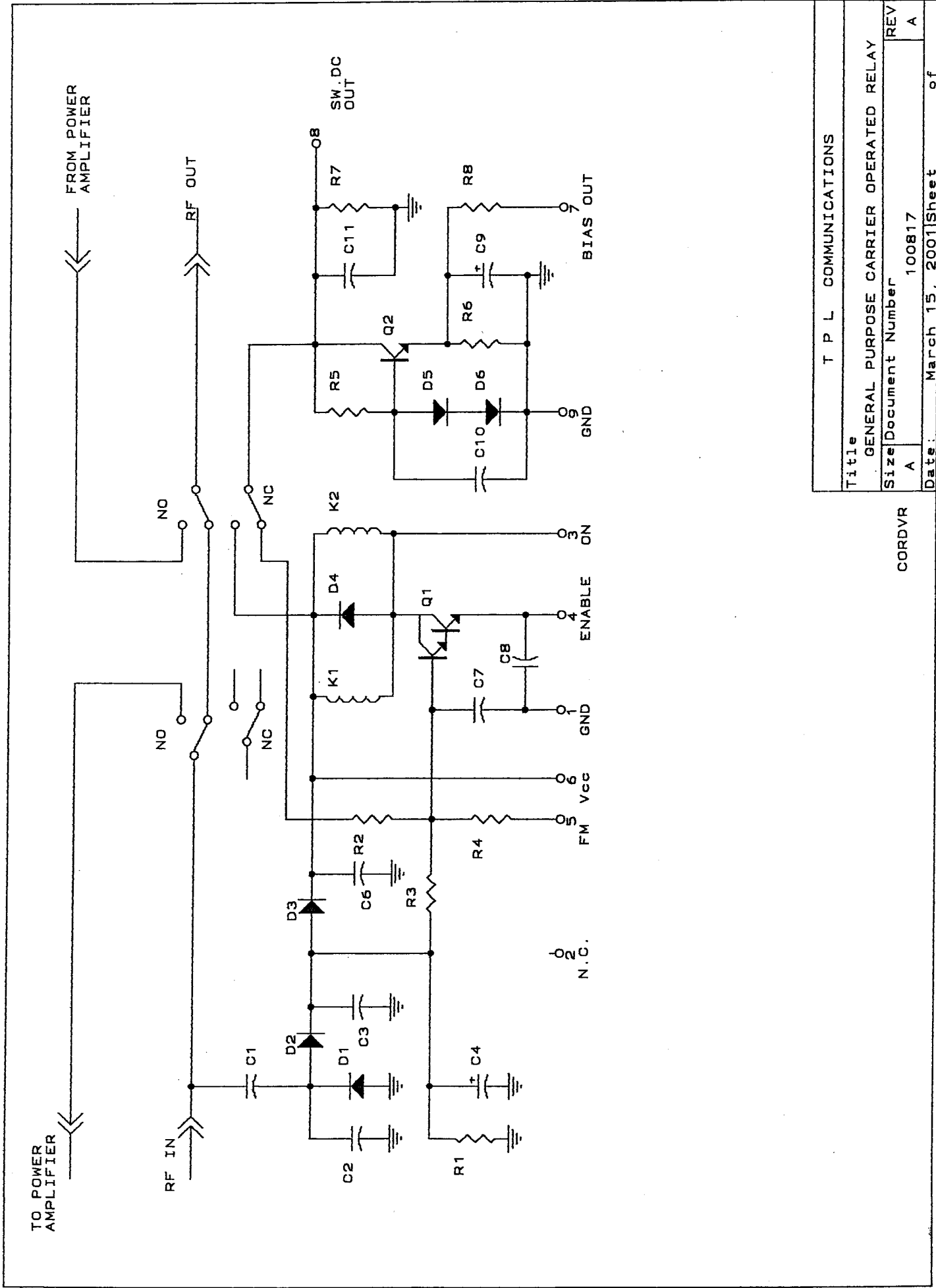

Title		T P L COMMUNICATIONS	
GENERAL PURPOSE CARRIER OPERATED RELAY			
Size	Document Number	100817	REV
A			A
Date:		March 15, 2001	Sheet
			of

CORDVR

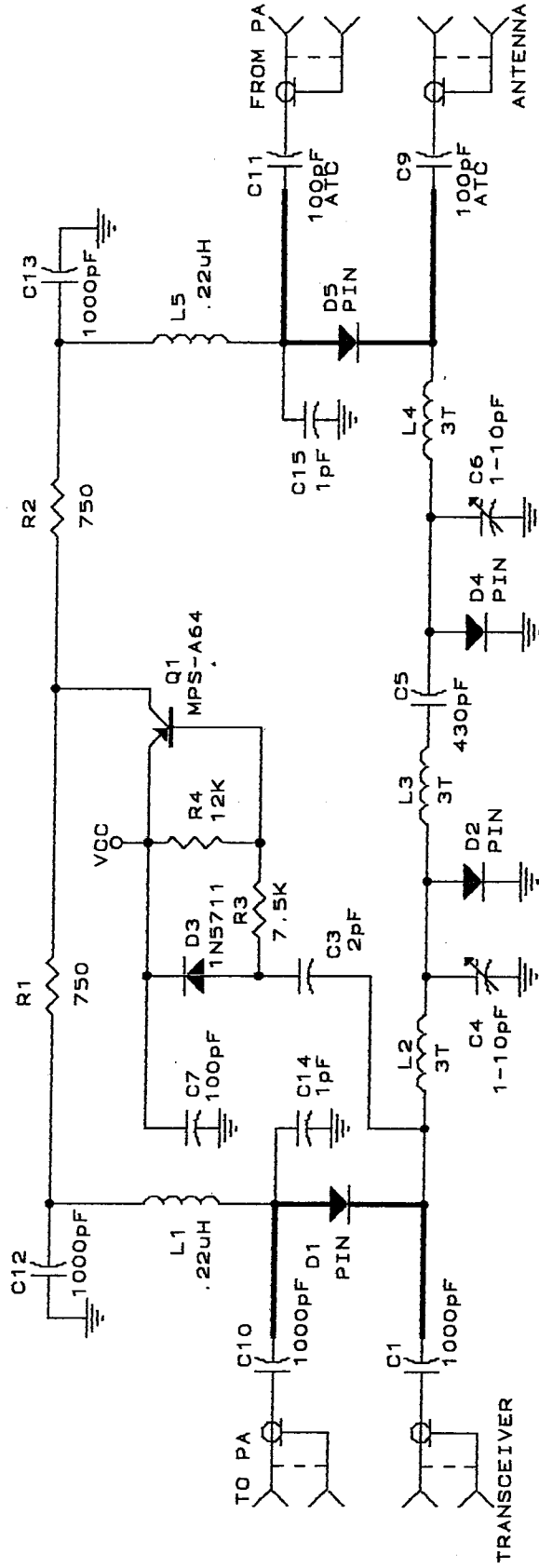

NOTES:

1. — MICROSTRIP Z = 50 Ohm

SSRCORU.SCH

TPL COMMUNICATIONS
LOS ANGELES CA

Title

SOLID STATE CARRIER OPERATED RELAY, UHF

Size Document Number

A 101370-U

Date: March 15, 2001 Sheet

of

RSPS CONFIGURATION

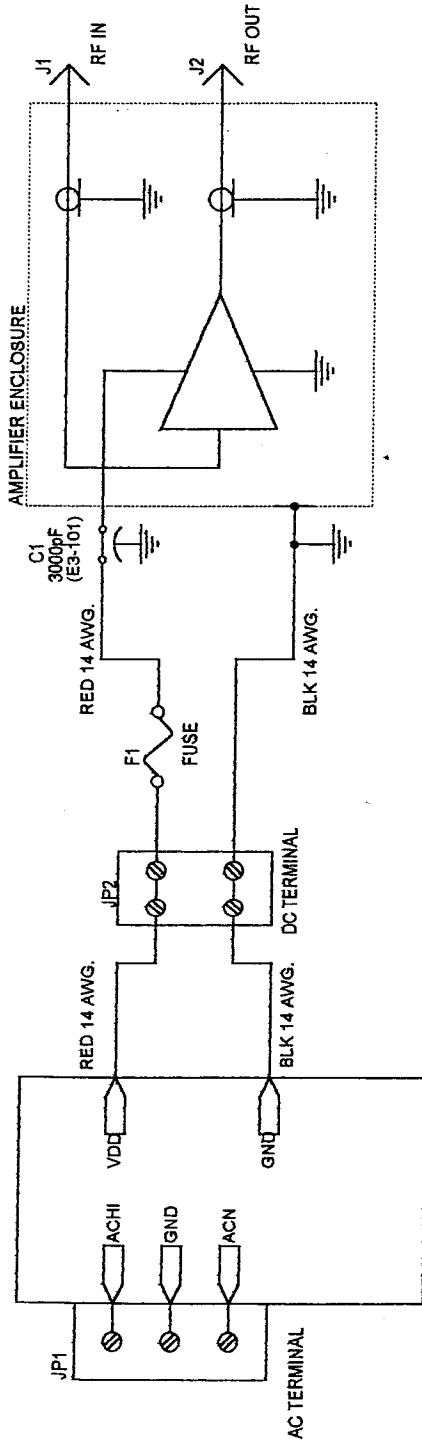

RS CONFIGURATION

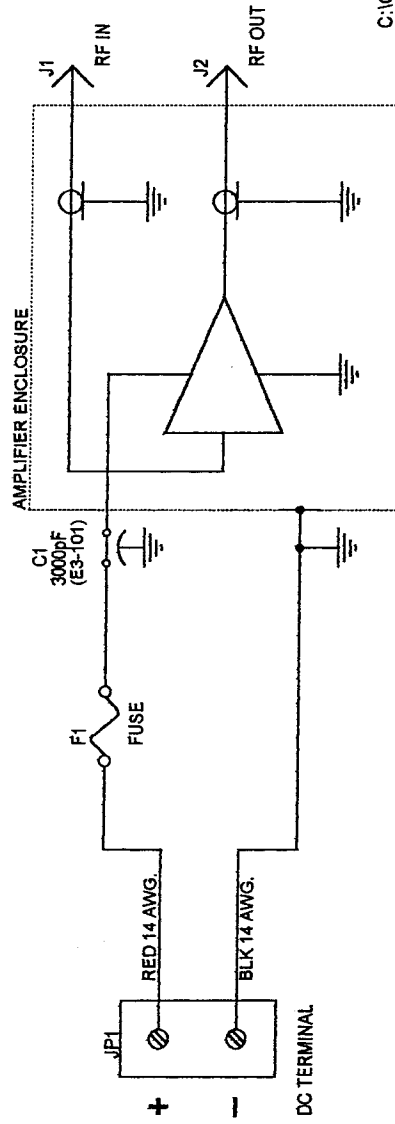

C:\ORCAD9_1\CAPTURE\SCHEMATIC\RS-WDG.DSN

T P L COMMUNICATIONS
LOS ANGELES, CA 90065

RS SERIES WIRING DIAGRAM

Title			
Size	A	Document Number	102409
Rev		Date	Thursday, February 22, 2001
Sheet	1	of	1

RXRFPFS & RXRF2PS CONFIGURATION

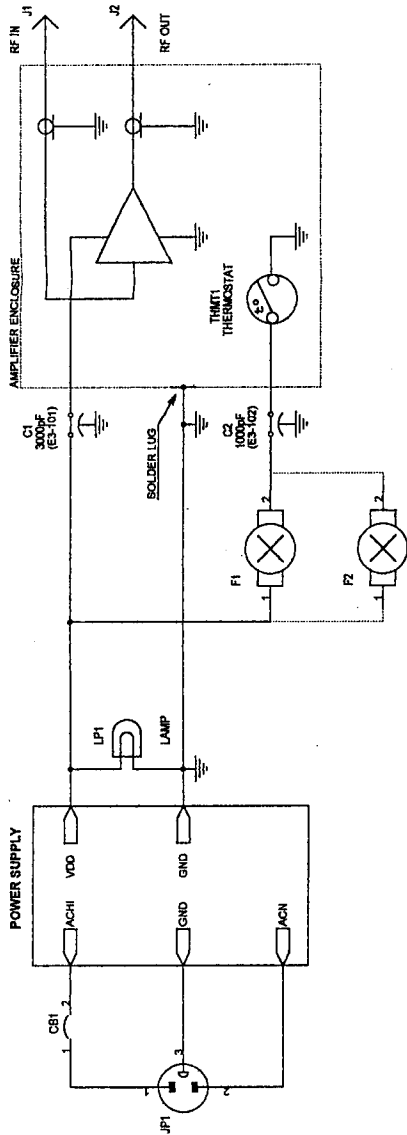

RXRF & RXRF2 CONFIGURATION

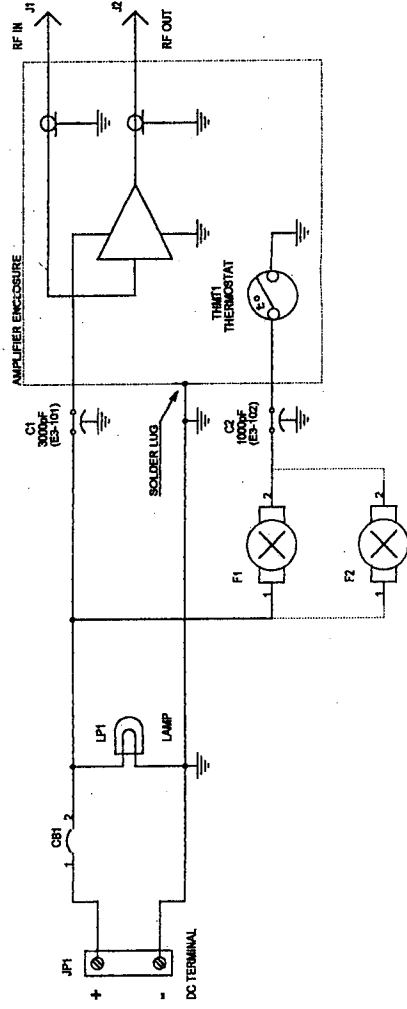

C:\ORCAD9_1\CAPTURESCHEMATIC\RXR-WO.DSN

T P L COMMUNICATIONS	
LOS ANGELES, CALIFORNIA 90065	
RXR SERIES WIRING DIAGRAM	
File	
Size	B
Document Number	102408
Date	Monday, February 18, 2001
Sheet	1 of 1

RXHF3PS CONFIGURATION

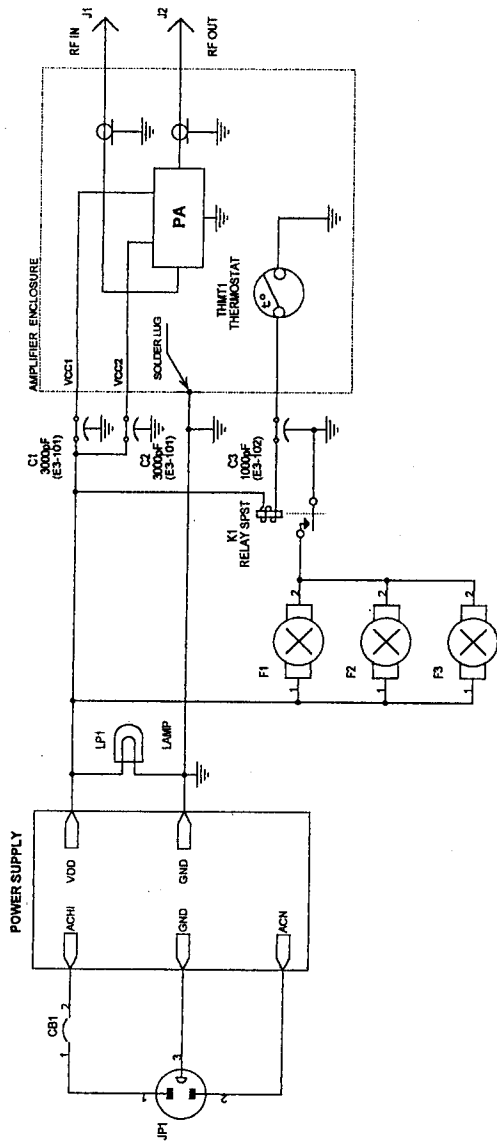

RXHF3 CONFIGURATION

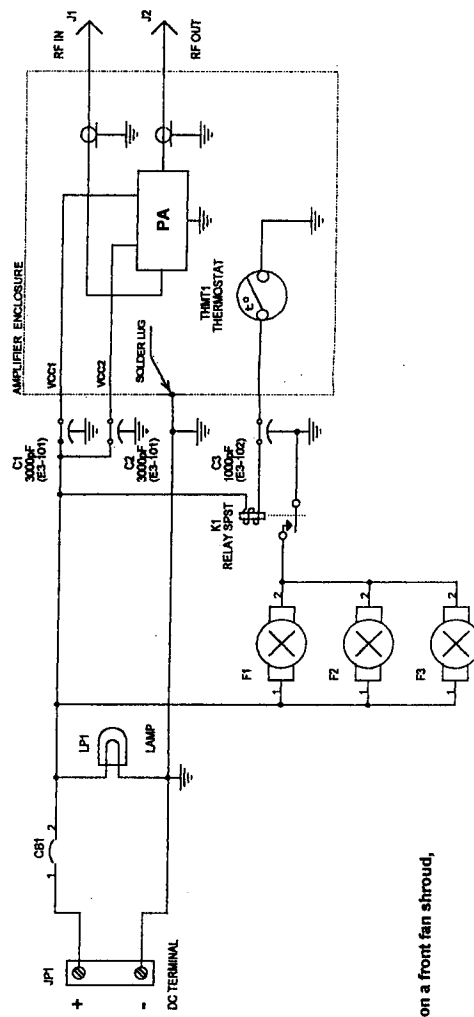

NOTES:

1. Cooling fans F1 and F2 are located on a front fan shroud, F3 is located on a RF deck cover.

TPL COMMUNICATIONS
 LOS ANGELES, CALIFORNIA 90065

Rev	1
Size	B
Document Number	102410
Date	Friday, February 23, 2001

PARTS LIST

Pre-driver stage Part No. T-101649-6-SA

REFERENCE NUMBER	PART DESCRIPTION	TPL PART NUMBER
	PCB	T-101649
C1,C2,C3	0.1uF Chip Cap.	A2-190
C4	1000pF Chip Cap.	A2-172
C5	10uF x 35V Tantalum Electrolytic Cap.	A4-127
C6	.1uF Dip Mica Cap. Hi Temp	A5-268A
U2	LM338 T Voltage Regulator	B7-189
U1	M57729H (or Equiv.) RF Module	B5-128
R1	620 Ohm 1/4W Res.	C1-167
R2	2.2kOhm 1/4W Res.	C1-180
R3	5k Pot.	C3-102A

PARTS LIST
(continued)

Pre-driver stage Part No. T-100327-P-D-SA

REFERENCE NUMBER	PART DESCRIPTION	TPL PART NUMBER
	PCB	T-100327
C1	100pF Cer. Disc Cap.	A1-148
C2,C9	1-10pF Air Var. Cap.	A5-600
C3,C4	25pF SEMCO Cap.	A1-104
C5	700pF SEMCO Cap.	A1-113
C6	33uF Axial Electr. Cap.	A4-113
C7,C12	.047uF Chip Cap.	A2-188
C8	50pF SEMCO Cap.	A1-106
C10	300pF SEMCO Cap.	A1-111
C11	1000pF Chip Cap.	A2-172
R1	33 Ohm ½ Res.	C1-336
R2	100 Ohm 2W Res.	C1-748
R3	100 Ohm 1W Res.	C1-548
Q1	MRF641 or SD1429-03	B2-127 (B2-115)
L1	1.0uH Choke ¼W.	E1-113
L2	5T; .25" DIA, #18 AWG.	E6-106
L3	10T; 3/16" DIA #18 AWG.	E6-126

PARTS LIST
(continued)

Driver stage Part No. T-100327-D-SA

REFERENCE NUMBER	PART DESCRIPTION	TPL PART NUMBER
	PCB	T-100327
C1	100pF Cer. Disc Cap.	A5-148
C2,C9	1-10pF Air Var Cap	A5-600
C3,C4	25pF SEMCO Cap.	A1-104
C5	33uF x 35V Electr. Cap.	A4-113
C6,C12	.047uF Chip Cap.	A2-188
C7,C8	35pF SEMCO Cap.	A1-105
C10	300 pF SEMCO Cap.	A1-111
C11	1000pF Chip Cap.	A2-172
Q1	MRF644 or SD1422	B2-120 (B2-116)
L1	1.0uH ¼W Choke	E1-113
L2	5T; .25" DIA; #18 AWG.	E6-106
L3	10T; 3/16" DIA; #18 AWG.	E6-126
R1	100 Ohm, 1W Res.	C1-548

PARTS LIST
(continued)

Driver stage Part No. T-100327-D-1-SA

REFERENCE NUMBER	PART DESCRIPTION	TPL PART NUMBER
	PCB	T-100327
C1	100pF Cer. Disc Cap.	A5-148
C2,C9	1-10pF Air Var Cap.	A5-600
C3,C4	25pF SEMCO Cap.	A1-104
C5	33uF x 35V Electr. Cap.	A4-113
C6,C12	.047uF Chip Cap.	A2-188
C7,C8	35pF SEMCO Cap.	A1-105
C10	300pF SEMCO Cap.	A1-111
C11	1000pF Chip Cap.	A2-172
Q1	MRF646	B2-142
L1	1.0uH ¼W Choke	E1-113
L2	5T; .25" DIA; #18 AWG.	E6-106
L3	10T; 3/16" DIA; #18 AWG.	E6-126
R1	100 Ohm, 1W Res.	C1-548

PARTS LIST
(continued)

Final stage Part No. T-100327-F-SA

REFERENCE NUMBER	PART DESCRIPTION	TPL PART NUMBER
	PCB	T-100327
C1	100pF Cer. Disc Cap.	A5-148
C2,C9	1-10pF Air Var Cap.	A5-600
C3	25pF SEMCO Cap.	A1-104
C4	30pF SEMCO Cap.	A1-104B
C5	33uF x 35 V Electr. Cap.	A4-113
C6,C12	.047uF Chip Cap.	A2-188
C7,C8	35pF SEMCO Cap.	A1-105
C10	300pF SEMCO Cap.	A1-111
C11	1000pF Chip Cap.	A2-172
Q1	MRF648	B2-141
L1	1.0uH ¼W Choke	E1-113
L2	5T; .25" DIA; #18 AWG.	E6-106
L3	10T; 3/16" DIA; #18 AWG.	E6-126
R1	100 Ohm; 1W Res.	C1-548

PARTS LIST
(continued)

Two-Way Power Splitter/Combiner Part No. T-100237-1

REFERENCE NUMBER	PART DESCRIPTION	TPL PART NUMBER
R1	100 Ohm 2W Res.	C1-758
T1,T2	75 Coax Cable	Z-RG179

Low Pass Filter Part No. T-100134-LPF-SA

REFERENCE NUMBER	PART DESCRIPTION	TPL PART NUMBER
	PCB	T-101383
C1,C4	10pF SEMCO Cap.	A1-101
C2,C3	20pF SEMCO Cap	A1-103
L1,L2,L3	Coil 1T, #16 AWG; .3" DIA.	E6-158

PARTS LIST
(continued)

UHF Carrier Operated Relay Part No. T-100816-R-SA*

REFERENCE NUMBER	PART DESCRIPTION	TPL PART NUMBER
	PCB	T-100816
R1	270 Ohm ¼W Resistor	C1-229
R2,R4	100kOhm ¼W Resistor	C1-220
R3	47kOhm ¼W Resistor	C1-212
C1,C2	1pF Dip. Mica Cap.	A8-100
C3	.01uF Cer. Disc Cap.	A5-244
C4	1.0uF 50V Electrolytic Cap.	A4-106
C6,C7,C8	.001uF Cer. Disc Cap.	A5-172
D1,D2	1N5711 Diode	B3-118
D3,D4	1N4148 Diode	B3-110
Q1	MPS-A14 NPN Darlington Transistor	B2-139
K1,K2	Relay, UHF	J1-101
R5	1.5kOhm ½W Resistor	C1-376
R6	47 Ohm ¼W Resistor	C1-140
R7	1.0kOhm ¼W Resistor	C1-172
R8	10 Ohm ¼W Resistor	C1-124
C9,C10,C11	.001uF Cer. Disc Capacitor	A5-172
D5,D6	1N4148 Diode	B3-110
Q2	TIP 31 NPN Transistor	B2-150

NOTE: *Only used on models with biasing

PARTS LIST
(continued)

UHF Carrier Operated Relay Part No. T-100816-R-1-SA

REFERENCE NUMBER	PART DESCRIPTION	TPL PART NUMBER
	PCB	T-100816
R1	270 Ohm ¼W Resistor	C1-229
R2,R4	100kOhm ¼W Resistor	C1-220
R3	47kOhm ¼W Resistor	C1-212
C1,C2	1pF Dip Mica Cap.	A8-100
C3	.01uF Cer. Disc Cap.	A5-244
C4	1.0uF 50V Electrolytic Cap.	A4-106
C6,C7,C8	.001uF Cer. Disc Cap.	A5-172
D1,D2	1N5711 Diode	B3-118
D3,D4	1N4148 Diode	B3-110
Q1	MPS-A14 NPN Darlington Transistor	B2-139
K1,K2	Relay, UHF	J1-101

PARTS LIST
(continued)

UHF Solid State Carrier Operated Relay Part No. T-100816-R-1-SA

REFERENCE NUMBER	PART DESCRIPTION	TPL PART NUMBER
	PCB	T-101369
C1,C10,C12,C13	1000pF Chip Cap.	A2-172
C7	100pF Chip Cap	A2-148
C3	2pF Cer. Disc Cap.	A5-107
C4,C6	1-10pF EP10 Trimmer Cap.	A5-708
C5	430pF Dipped Mica Cap.	A8-163
C2,C8	1pF Chip Cap.	A2-100A
C9,C11	100pF ATC Chip Cap.	A2-191
D1,D2,D4,D5	MA47266 Diode	B3-115A
D3	1N5711 Diode	B3-118
L5,L1	0.22uH Choke	E1-111
L2,L3,L4	Coil 3 Turns #22 AWG.	E1-123
Q1	MPS-A64 Transistor PNP	B2-106
R1,R2	750 Ohm Resistor ½W	C1-369
R3	7.5kOhm Resistor ¼W	C1-193
R4	12kOhm Resistor ¼W	C1-198

WARRANTY

TPL Communications has tested and found this unit to function properly and to operate within the parameters of its stated specifications.

TPL Communications warrants that this product is free from defects in material and workmanship. If found to be defective within two (2) years from the date of purchase, the factory will, at its discretion, either repair or replace the unit at no cost, provided the unit is delivered by the owner to the factory intact. The warranty does not apply to any product which has been subjected to misuse, neglect, accident, improper installation, or used in violation of instructions furnished by us, nor does it extend to units which have been repaired or altered outside our service department, nor where the serial number has been removed, defaced or changed.

SERVICE

For service on this amplifier, contact:

TPL Communications
Customer Service Department
(323) 256-3000
800 HI POWER
FAX (323) 254-3210
E-Mail: tplcom@usa.net